

## Arduino Look and Feel for Multicore

---

Marcus Gößler

MicroConsult GmbH

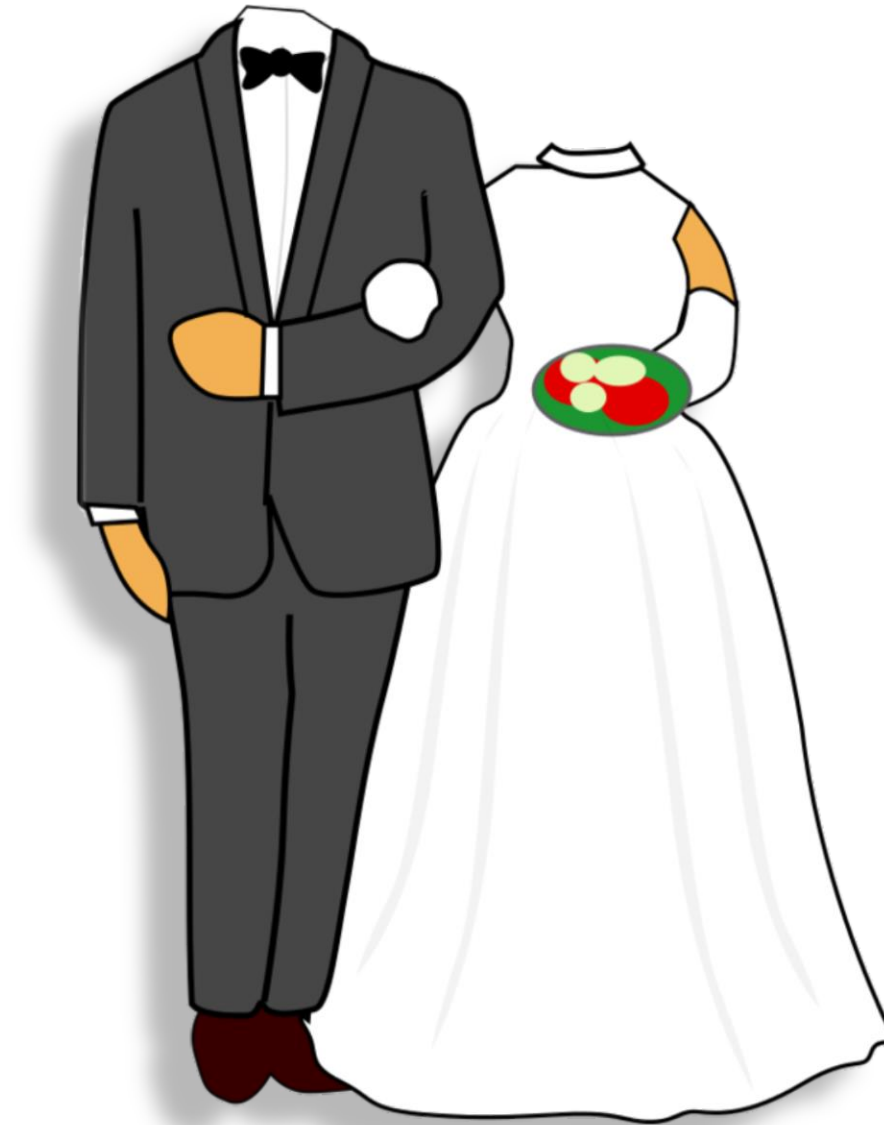

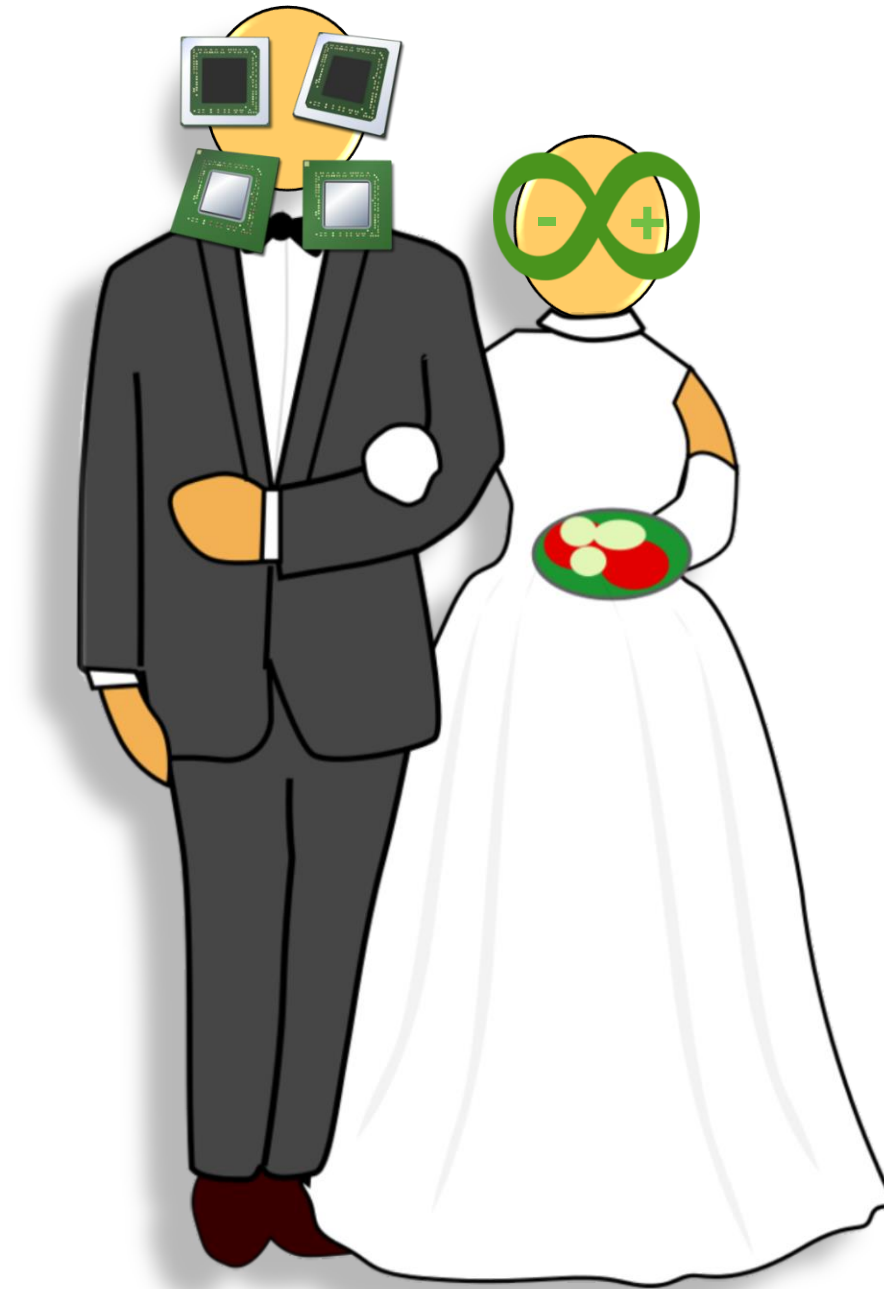

## Content

- **Multicore Benefits**
- **Multicore Challenges**
- **Arduino Brief**
- **Multicore and Arduino**
- **Example AURduino**
- **How to?**
- **Outlook**
- **Conclusion**
- **Demo**

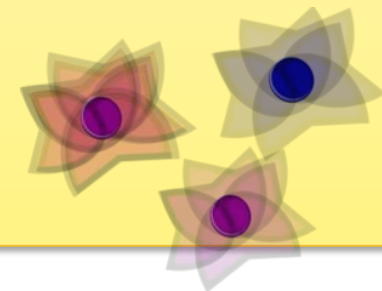

## Profile

<b>Age:</b>	20+
<b>Size:</b>	2 – many
<b>Weight:</b>	lightweight but powerful
<b>Hobbies:</b>	not really
<b>Profession:</b>	Executor
<b>Favorite food:</b>	LOC
<b>Parents:</b>	IBM, TI, ...
<b>Hometown:</b>	embedded systems and computer



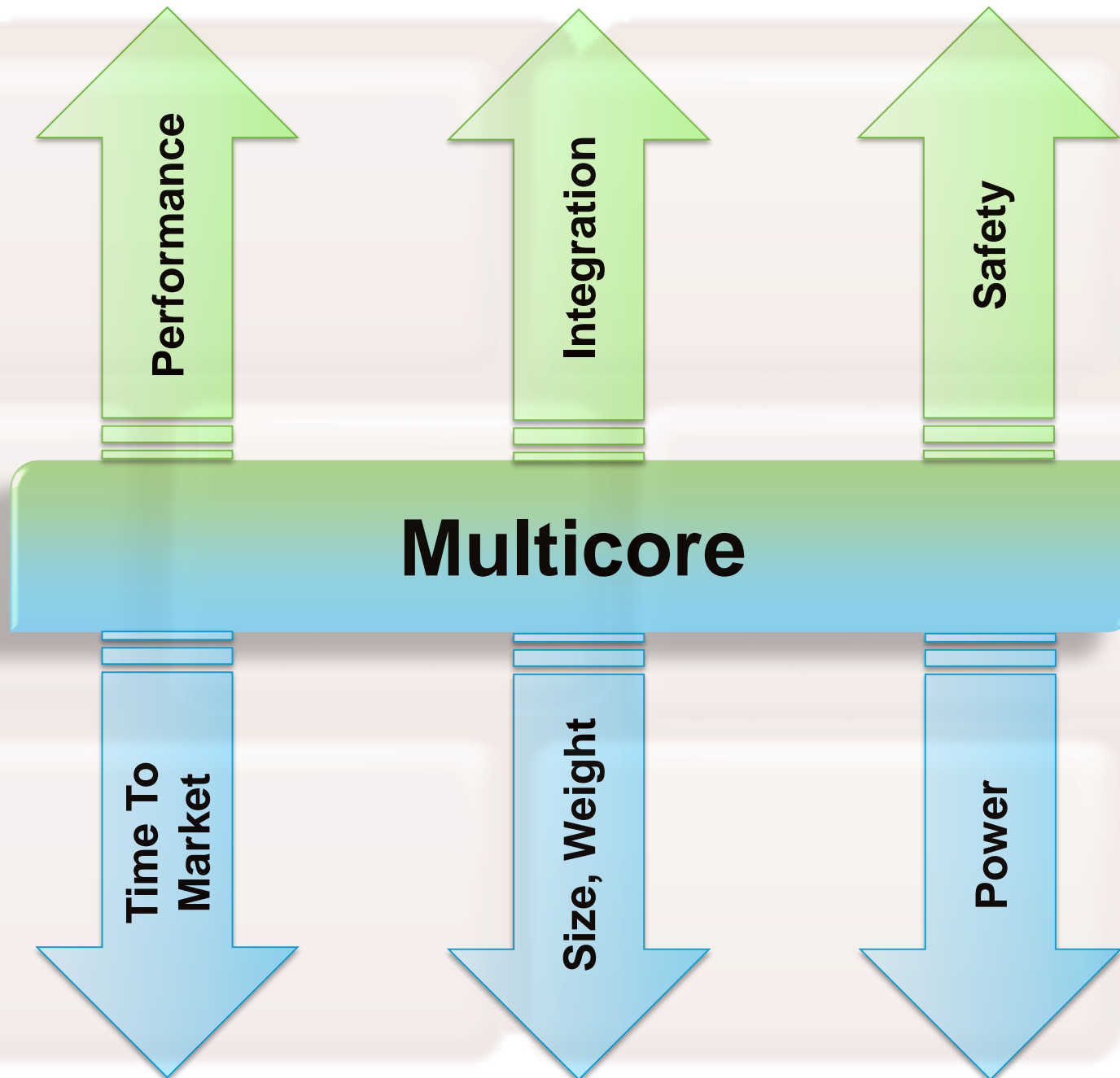

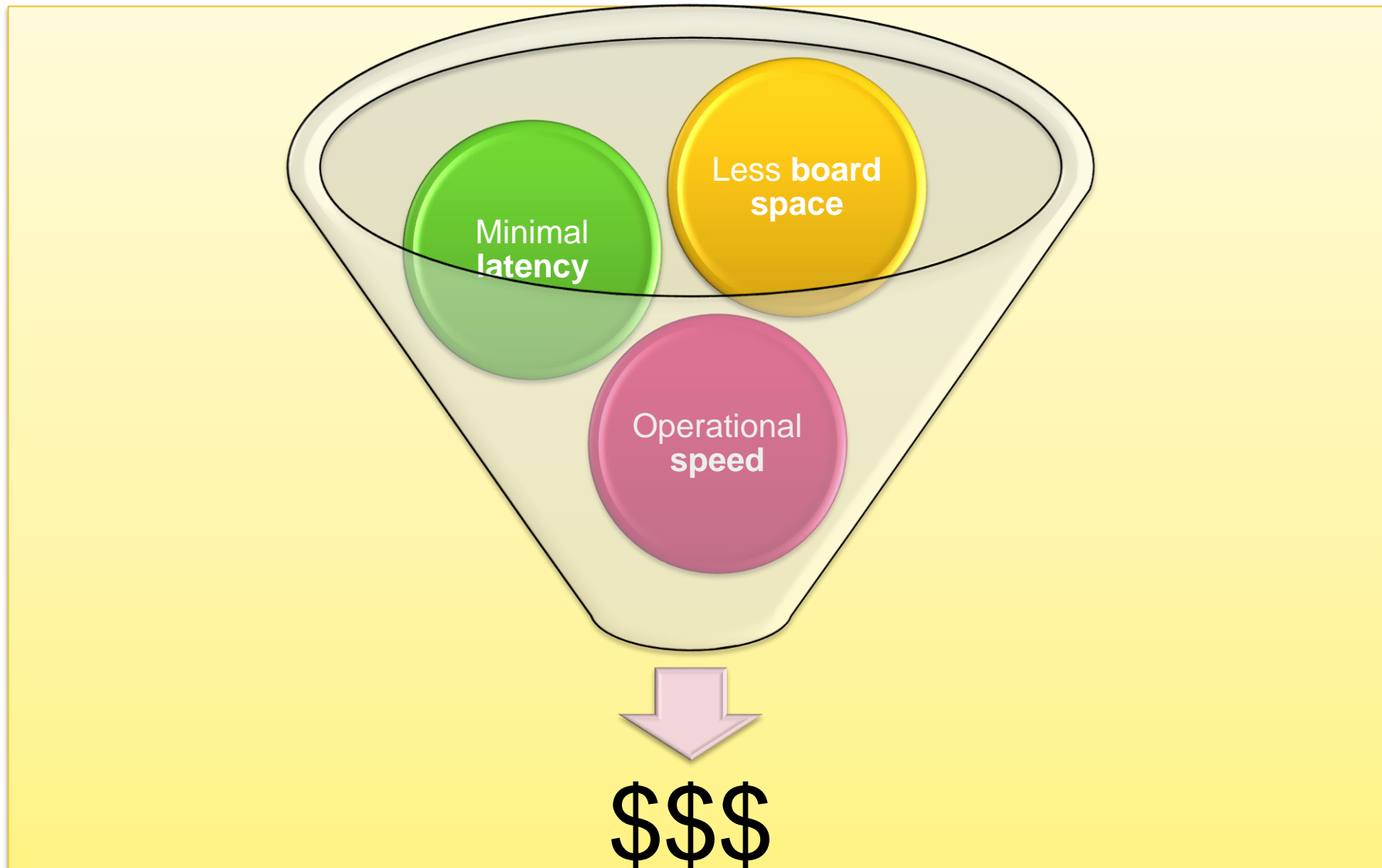

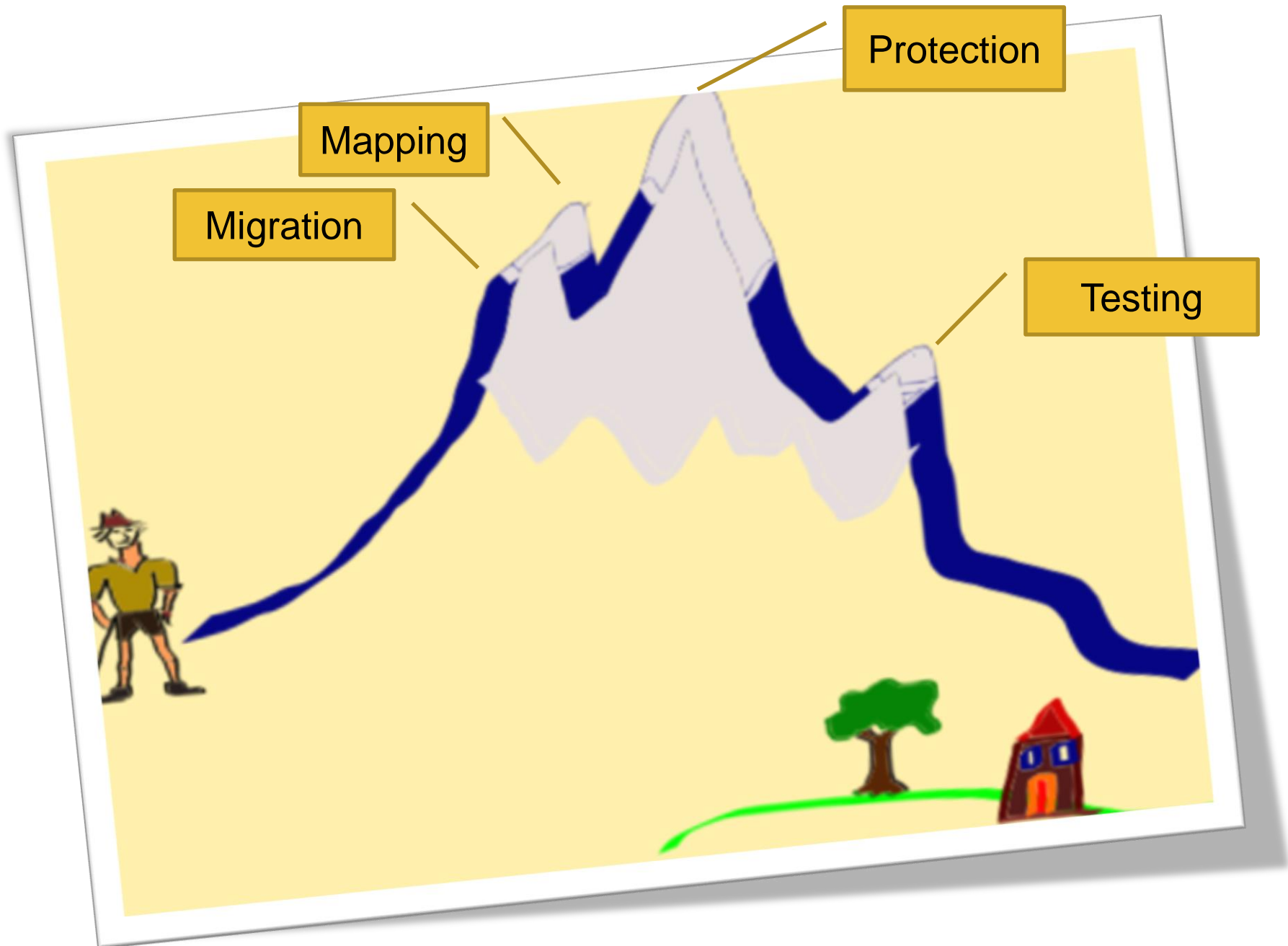



## Profile

<b>Age:</b>	11
<b>Size:</b>	68.6 mm x 53.4 mm
<b>Weight:</b>	Millions of ...
<b>Hobbies:</b>	Robotic, Home automation, ...
<b>Profession:</b>	Teacher
<b>Favorite food:</b>	LOC
<b>Parents:</b>	Massimo Banzi, David Cuartielles, Tom Igoe, Gianluca Martino, David Mellis
<b>Hometown:</b>	Ivrea (Italy)

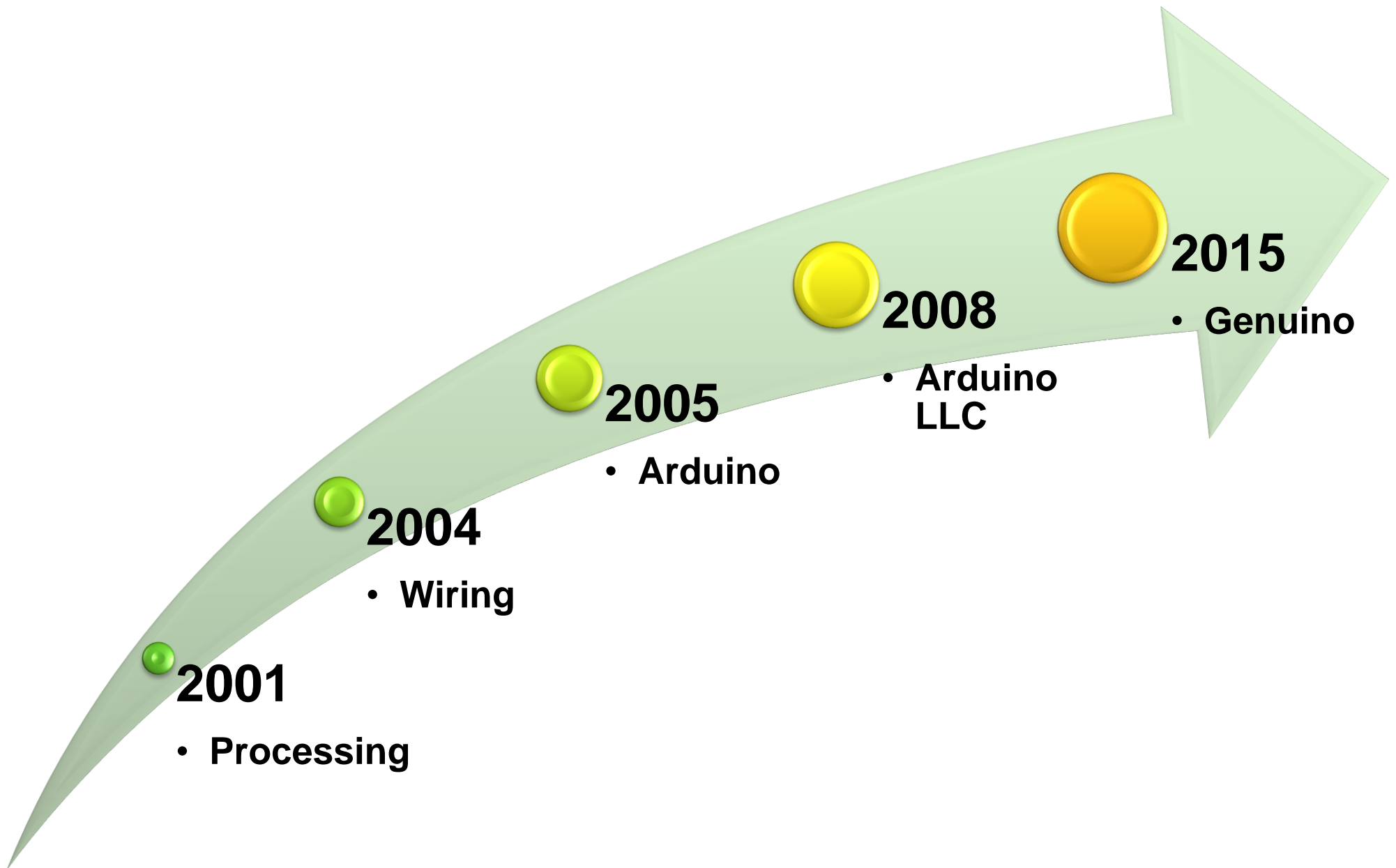

# Intel Edison Kit for Arduino

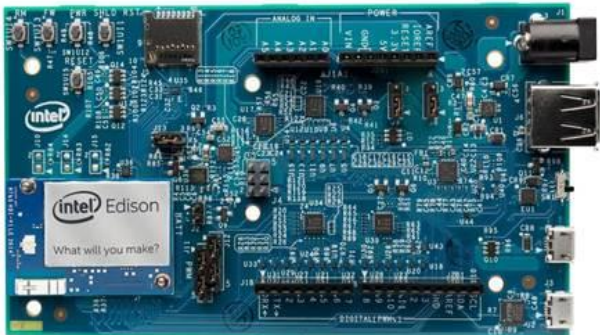

Ref. Intel

# Arduissimo



Ref. INDIEGOGO

# UDOO Neo



Ref. UDOO

**Low cost** AURIX TC275 board for professional and hobby use  
Uses Arduino™ Due/Mega2560 **form factor** and IO connector pin allocation

Safety Hitex Shield BuddyTC275 option with on-board CIC61508 safety monitor for use with SafeTlib

Instant access to over 317 **shields**

Supplied with **basic drivers** for  
DS-ADC, SAR, GTM, GPT,  
CCU6, ASC, LIN, SPI, QSPI, Ethernet

Direct **USB debug** interface

Development tools based on HighTec  
**Free** Aurix Toolchain and Arduino IDE

USB or 9-12V power supply

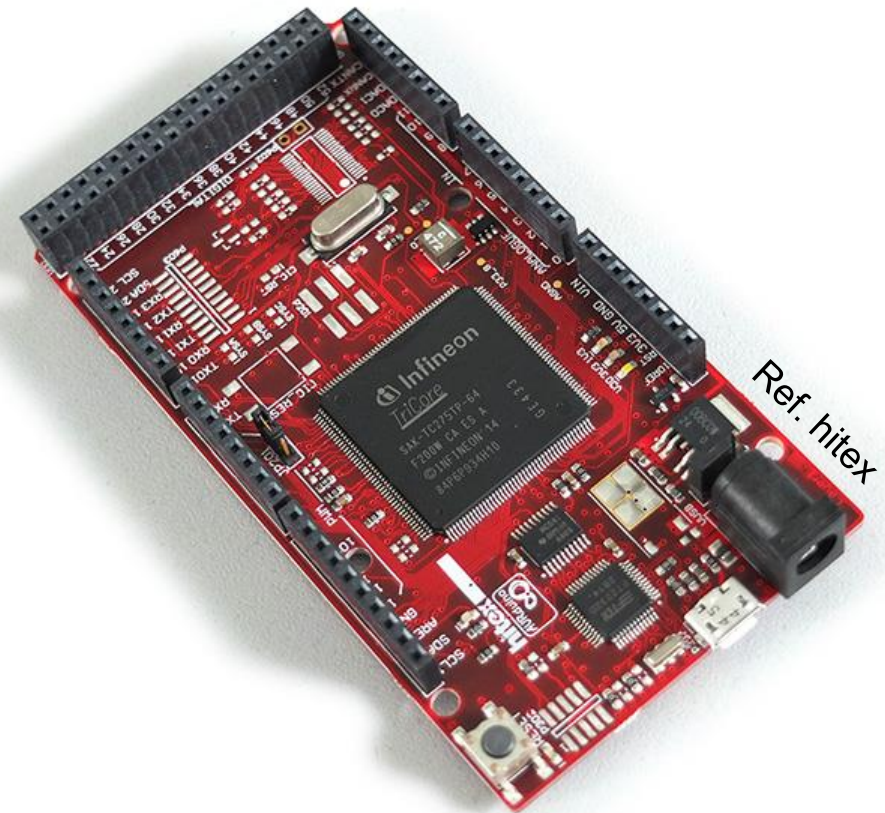



Toolbar Buttons  
(Verify, Upload, New, Open, Save, Serial Monitor)

Message Box

Console

Sketch

Hardware Info

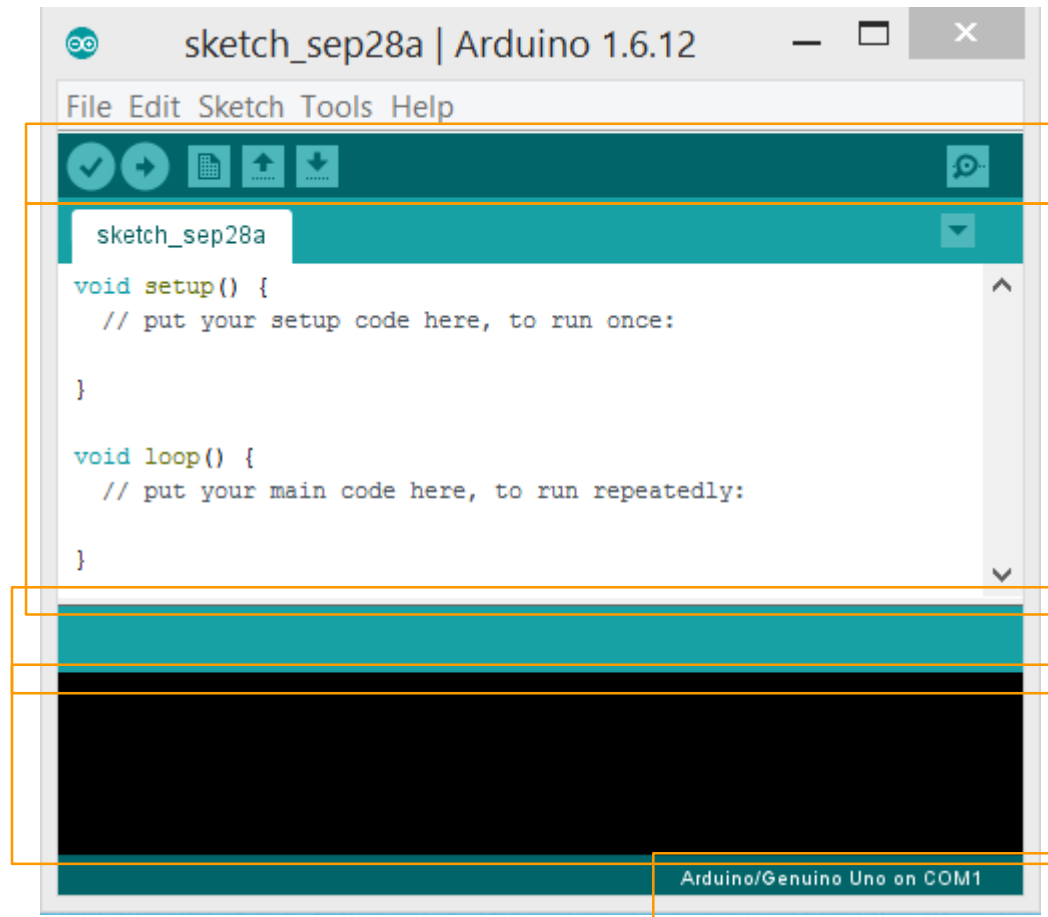

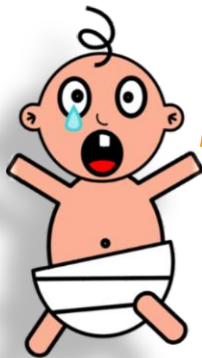

```

sketch_sep29a | Arduino 1.6.12
File Edit Sketch Tools Help

sketch_sep29a $

/** Core 0 **/
void setup() {
  // put your setup code for core 0 here, to run once:
  // initialize digital pin LED_BUILTIN as an output.
  pinMode(LED_BUILTIN, OUTPUT);
}

void loop() {
  // put your main code for core 0 here, to run repeatedly:
  digitalWrite(LED_BUILTIN, HIGH); // turn the LED on (HIGH is the voltage level)
  delay(1000); // wait for a second
  digitalWrite(LED_BUILTIN, LOW); // turn the LED off by making the voltage LOW
  delay(1000); // wait for a second
}

/** Core 1 **/
void setup1() {
  // put your setup code for core 1 here, to run once:
}
void loop1() {
  // put your main code core 1 here, to run repeatedly:
}

/** Core 2 **/
void setup2() {
  // put your setup code for core 2 here, to run once:
}
void loop2() {
  // put your main code core 2 here, to run repeatedly:
}

```

23 Arduino on COM1

HighTec - ArduinoMulticoreUser/Sketches/BoardEOLtest.cpp - HighTec Development Platform Runtime

File Edit Source Refactor Navigate Search Project Run Window Help

Quick Access HighTec

HighTec Project Explorer

- Aurduino
- AurduinoMulticore
- AurduinoMulticoreUser - 4.6.6.1 - iROM - [a**
  - Binaries
  - Includes
  - aurix
  - iROM
  - Sketches
    - BoardEOLtest.cpp**
    - Empty.cpp
    - EthernetSketch.cpp
    - LCDExample.cpp
    - main\_analog.cpp
    - main\_gtm.cpp
    - main\_i2c.cpp
    - main\_SD.cpp
    - main\_serial.cpp
    - main.cpp
    - MotorShield.cpp
    - shapes.cpp
    - Sketch.cpp
  - includes.opt
  - makefile.defs
  - makefile.init
  - makefile.targets
  - AurduinoUser
  - iLLD\_Lib\_Make

BoardEOLtest.cpp

```

/* Allow use of VT100 escape sequences */
#include "vt100.h"

/* Simple Board Test Sketch */

char rxdata;

void setup() {
    // put your setup code here, to run once:

    SerialASC.begin(9600);

    SerialASC.print(VT100_CURSOR_OFF);
    SerialASC.print(VT100_CLR_SCREEN);

    SerialASC.print("Test AURduino RevB");
    SerialASC.print("\n\rPress any key to \n\rproceed with te

    rxdata = char(SerialASC.read());
    SerialASC.print("\n\rReceived: ");
    SerialASC.print(rxdata);
  
```

Problems Tasks Properties

27 errors, 5 warnings, 0 others

Description	Resource	Path
Errors (27 items)		
Warnings (5 items)		

Writable Smart Insert 1:1

iLLD

## Initialization of the configuration structure

```
<Driver Prefix>_initConfig(<Driver Prefix>_Config *cfg);
```

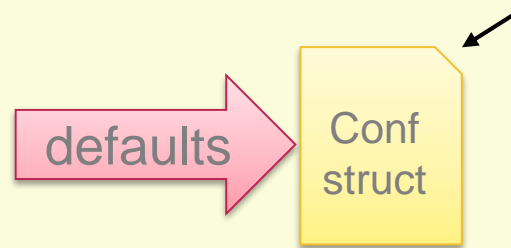

## Driver Initialization

```
<Driver Prefix>_init(<Driver Prefix>_Handle *handle, <Driver Prefix>_Config *cfg);
```

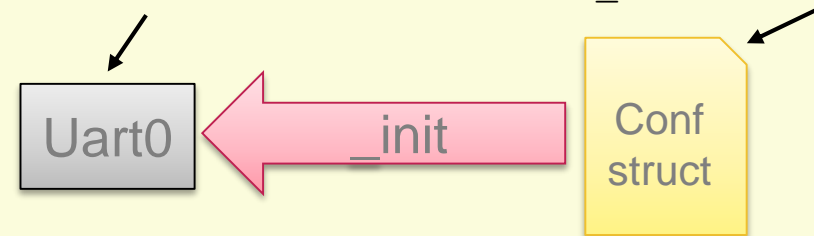

## Driver De-Initialization

```
<Driver Prefix>_deInit(<Driver Prefix>_Handle *handle);
```

## iLLD functional APIs

```
<Driver Prefix>_<functionality>(<Driver Prefix>_Handle *handle);
```

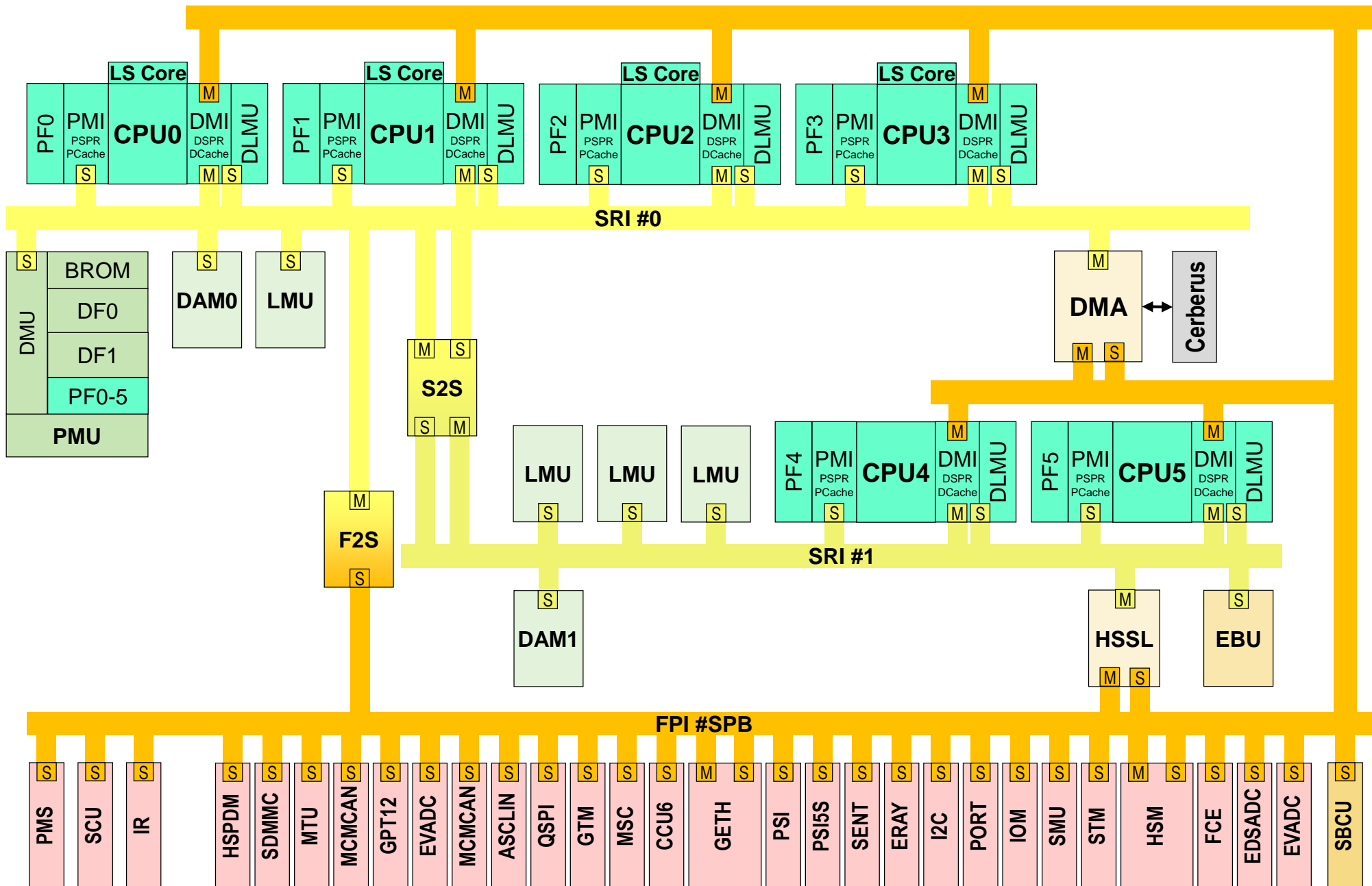

**Can Arduino help to get started quickly on Multicore?**



**Do Arduino style boards provide a cost-effective platform?**



**Is it an intuitive way to program?**



**Does Arduino help to maintain complex Multicore scenarios?**



**Does it provide means to deeply debug your system?**



**Will your functional safety application benefit from Arduino?**



# MicroConsult Training & Coaching on Multicore:

[www.microconsult.de](http://www.microconsult.de)

**Contact:**

Marcus Gößler

Phone +49 89 450617-37

[m.goessler@microconsult.de](mailto:m.goessler@microconsult.de)